

# DESIGN AND DEVELOPMENT OF A CRAB SHELL GRANULATING MACHINE

MICHAEL A. ALORIA, IMMER MIKO R. ADAME, ANDRIO D. BAUTISTA, AND CHRISTOPHER IMPERIAL

*Mechanical and Petroleum Engineering Department  
College of Engineering, Architecture & Fine Arts  
Batangas State University*

**Abstract:** This study investigated the performance of a developed crab shell granulating machine for organic fertilizer production. Various parameters were tested in terms of operating conditions of the machine and its actual performance in terms of granulating rate and efficiency. The dried blue crab shells were used as the raw materials for performance testing. The properties of the final product output were tested to determine its properties. Results revealed that the operating speed of the machine was 1200 rpm, with an operating capacity of 750 g, and granulating time of 89 seconds. The average granulating rate and efficiency were 8.07 g/s and 96%, respectively. Laboratory analyses showed that the nitrogen, phosphorous, and potassium contents of the product output were 4.05%, 1.13%, and 0%, respectively. The obtained nitrogen, phosphorous, and potassium values were comparable to their theoretical values and can be considered as potential organic fertilizer. The moisture content of 7.45% and pH level of 8.85 (standard range of 6.6 to 9.5) were also acceptable for application. Further study may be conducted focusing on the application of the product output to various vegetable crops to determine the effectiveness of the crab meal fertilizer.

**Keywords:** *crab shells, granulating rate, granulating efficiency, operating speed, operating capacity*

## 1. INTRODUCTION

Crab culture provides income and livelihood to many Filipinos. It is considered as a minor fishery product, but it is now an export commodity and a foreign exchange earner. Crab, being a supplementary crop from brackish water milkfish and shrimp ponds, has virtually been overlooked as a potential species for culture. Nowadays, crabs, one of the aquatic commodities, command high prices in both domestic and foreign markets. This triggered the development of crab industry in the Philippines. The most common species of crab harvested for local consumption and export are the mudcrab (*Scylla serrata*), known as *alimango*, and blue crab (*Portunus pelagicus*), known as *alimasag*.

Crabs have become one of the favorite foods in many seafood restaurants in the country. They are sought for their tasty meat and rich-flavored ripe eggs in the ovary. The increasing demand for crabs here in the country has opened doors to the development of crab aquacultures, which provide a source of income to fishermen, and crab picking plants for crab meat processing. This provides greater opportunities to develop its full potentials on different fields like agriculture, medicine, and food industry.

Muir (2006) states that blue crabs are found throughout Asia and Australia, as well as along the east coast of Africa. They have an average mass of about 300 grams and, like all crustaceans, turn orange when cooked. They are one of the few crabs sold dead but

uncooked, but are not sold live as they don't survive well, once captured. They yield about 35% meat and have a sweet taste, nutty, and slightly milder and softer than that of mangrove crabs. Considering that amount of yield extracted as crab meat, the remaining 65% is considered as waste crab shells.

Organic fertilizers are produced from agricultural wastes, animal by-products and other organic materials. According to Dela Cruz *et al.* (2006), organic-based agricultural production is considered a rapidly emerging technology in the Philippines, which partly addresses the increasing problem on solid waste disposal. Conversion of biodegradable wastes into organic fertilizer would ensure its availability for crop production. This will not only provide an increased income for the farmers but also a stable source for improving the physical and chemical properties of soil, hence sustaining soil health and productivity. With the increasing living level and green food demand, most farmers aim to enhance the market competitiveness of their agricultural products through improved crops quality. This entails continuous supply of organic fertilizers to meet the increasing market needs.

Food wastes are good raw materials for the production of organic fertilizer. One of these food wastes is from the shells of crustaceans such as crabs and lobsters. These shells are very high in nutrients that create a growing environment for vegetables and other crops. Processing of crab shells into useful output like fertilizer would be an alternative to seize and unleash its potential to contribute to the greater society. Crab shell is an excellent dry organic source of sodium, phosphorous, potassium, calcium (23%), and magnesium (1.33%). It is high in chitin, which promotes the growth of chitin eating bacteria in the soil. Only a small portion of crab shells is being used for chitin production. With annual world crab production exceeding 2 million tons with China as the top producer, there is a lot of unused potential for crab shells to be a sustainable natural resource since 1.5 million tons of crabs are consumed every year, generating about 0.5 million tons of crab shells as waste (Yao *et al.*, 2013). Crab meal organic fertilizer which contains chitin protein protects the plants and provides a healthy growing process without the use of pesticides and harmful chemicals. Crab meal provides a slow release of nitrogen into the soil.

The most popular, government-supported farming programs in the country are into sustainable agriculture (Maghirang *et al.*, 2012). These organic food production systems maintain biodiversity, ecological balance, sustainability, natural plant fertilization, natural pest management, and soil integrity. Organic farming excludes or strictly limits the use of manufactured fertilizers, pesticides, herbicides, insecticides and fungicides. Hence, organic fertilizer production should be given more focus to ensure sustainable organic farming. This study therefore seriously focused on developing a crab shell granulating machine for crab meal fertilizer production. This produced an economical design of the machine utilizing the dry granulation process. Dhenge *et al.* (2012) discuss how the dry granulation process is a simple and low cost method used to form granules without using a liquid solution since the desired granulated product is sensitive to moisture and heat. Compacting and densifying the powders form granules without moisture. In this process, the primary powder particles are aggregated under high pressure. It uses mechanical compaction to facilitate the agglomeration of dry powder particles. Hence, this study focused on the performance evaluation of the fabricated granulating machine taking into consideration various operating conditions such as granulating time and operating speed and capacity, and performance parameters like granulating rate and efficiency.

## 2. METHODOLOGY

This study was carried out using engineering design and process analysis to attain the set objectives. It involved performance and experimental testing to evaluate the fabricated machine, which entailed analyzing the different parameters to achieve the expected outcome. This covered the following stages:

*Design stage.* This stage was focused on the engineering calculations to determine the specifications of various materials used for fabrication. Schematic layout of the proposed machine was presented specifying the different system components and dimensions.

*Development stage.* This stage covered the fabrication of the machine, taking into consideration the design specifications. Availability and cost were considered in the proper selection of materials.

*Preliminary testing stage.* Preliminary testing of the machine was conducted to establish the operating parameters of the fabricated machine such as maximum feeding capacity, operating speed, and granulating time. During this stage, some modifications were incorporated to rectify the problems encountered during initial operation. It also included several trial runs to come up with the desired operating conditions of the machine.

*Final performance testing stage.* In the final testing, the performance of the machine was tested in terms of granulating rate and granulating efficiency.

*Experimental testing stage.* The samples of the final product collected during the performance evaluation were tested to determine the properties in terms of moisture content, pH level, nitrogen content, phosphorous content and potassium content.

### *Preparation of raw materials*

The first step in the preparation of raw materials was the collection of leftover blue crab shells from households and restaurants located in Batangas City. The crab shells were washed in water until the remaining crab meat was removed. The legs and claws were cut at the joints. Those carapaces larger than 102 mm (4 in) were cut into smaller pieces. The shells were then boiled to remove the spines. The boiling process took 30 to 45 minutes. Boiled crab shells were drained on paper towels allowing them to cool. The cooked crab shells were sun dried for two (2) days.

### *Operating procedures*

The dried crab shells to be fed into the machine were prepared. The machine was mounted on a flat surface for it to be stable during operations. Using the machine on uneven surfaces may cause it to vibrate violently while it is in operation. This may damage the moving parts of the machine as well as cause hazards and accidents. All machine components were checked before operation. The machine was plugged to the three-phase power outlet.

The dried crab shells were put into the hopper carefully and were covered for safety purposes. Before starting the machine, the cover and the catchment drawer were checked to ensure that they are tight and properly positioned. The reset and start button on the variable frequency drive was pressed to set the frequency of the machine at 40 Hertz.

The switch was turned on to start the granulating process. After 1 minute and 30 seconds, the switch was turned off to ensure that all the crab shells were granulated. The granulated crab shells from the catchment drawer were then collected.

#### *Methods of testing for determining operating conditions*

The following were considered to define the operating conditions of the machine:

##### *1. Method of determining maximum feeding capacity*

Maximum feeding capacity was determined by feeding different amounts of dried crab shells in the hopper. The maximum feeding capacity was chosen on the basis of the maximum amount of dried crab shells the machine could process.

##### *2. Method of determining operating speed*

Operating speed was determined by conducting several trials that gave the machine optimum operation and maximum efficiency.

##### *3. Method of determining granulating time*

The granulating time was determined by measuring the time it took to granulate the crab shells. The granulating time started at the time the crab shells were fed into the machine and ended when all the raw materials were granulated.

#### *Methods of testing performance parameters*

The performance of the crab shell granulating machine was determined after the data in preliminary testing were obtained. The tests were done in three (3) trials, and different parameters of the machine were evaluated.

##### *1. Method of determining the granulating rate*

The granulating rate was determined in terms of the ratio of the weight of the crab shell granules and the time of granulation.

$$G_R = \frac{M}{T}$$

where:

- $G_R$  = granulating rate
- $M$  = mass of granulated crab shells (g)
- $T$  = granulating time (sec)

## 2. Method of determining the granulating efficiency

The efficiency of the machine was identified by the ratios of the total weights of the crab shell granules and the dried crab shells fed in the machine.

$$E = \frac{Mg}{Mf} \times 100\%$$

where:

- E = efficiency  
 Mg = mass of granulated crab shells (g)  
 Mf = mass of feed (dried crab shells) (g)

## 3. Method of testing the properties of the crab shell granules

The testing of the properties of the crab shell fertilizer was done after appropriate sampling of the product output. The sample output was tested at the Lipa Quality Control Center for nitrogen content, phosphorus content, potassium content, moisture content, and pH level.

### Materials specifications and costs

Table 1 shows the specifications and costs of the materials used in the fabrication of the prototype.

Table 1. List of materials used in the fabrication of the prototype, their specifications and costs.

Parts	Materials	Size and Specifications	Cost (Php)
Frame	Angle bar	1 ½ in. x 1 ½ in.	5,000
	Plate(Carbon steel)	1/8 in. thick	
Hammer Mill	Plate(Carbon steel)	¼ in. thick	20,000
	Shaft	¾ in. diameter	
	Pillow block Bearings		
Variable Frequency Drive	Screen	4mm diameter	5,000
	Motor	2hp	
Coupling, Shim Plate, Key block		2hp, 3-phase, 220V	5,000
	Electrical Materials		
Other Miscellaneous	Paint		7,000
	Consumable Materials		
Labor Cost			7,000
		<i>Total Cost</i>	<i>51,500</i>

### 3. RESULTS AND DISCUSSION

#### 3.1 Design and Development of the Prototype

The schematic layout of the crab shell granulating machine is shown in Figure 1. It shows the complete assembly of the machine. Figure 2 provides the final set-up of the machine.

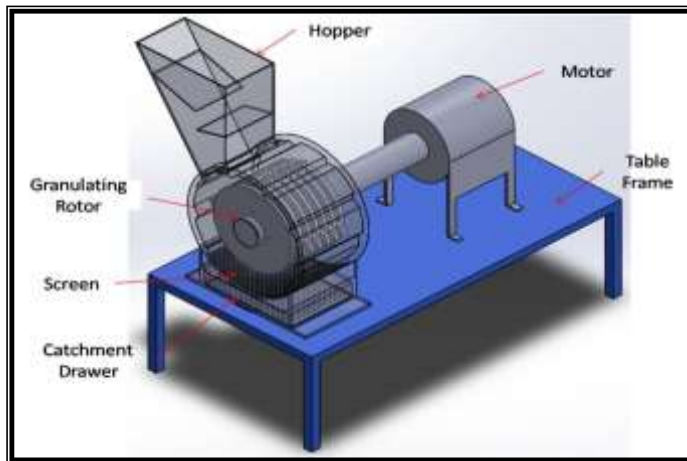

Figure 1. Schematic layout of the crab shell granulating machine.



Figure 2. The final set-up of the machine.

### 3.2 System Components and their Functions

The fabricated machine is comprised mainly of the granulating rotor, hopper, screen, catchment drawer, variable frequency drive, and electric motor.

The granulating rotor is responsible for the granulating process which turns the dried crab shells into granules. It is made of carbon steel metal plates with a thickness of 5 mm. It is composed of round metal plates and hammers. The round metal plates have a diameter of 230 mm concentrically aligned for stability. There are two types of hammers: movable and fixed. These are alternately aligned for effective granulating. The movable hammers have a length of 62 mm and the fixed ones are 115 mm long. Both are cut at an angle of 33.56 degrees from horizontal axis.

The hopper of the machine has opening dimensions of 280 mm x 152 mm. This is where the crab shells are fed into the machine and serves as its inlet to the granulating chamber where the granulating process is facilitated. The screen is installed in the machine, which filters the crab shell granules before it leaves the granulating chamber to ensure the required particle size. It has a sieve size of 4 mm, which is the target size of the end product. The catchment drawer serves as the discharge basin of the machine. The drawer has dimensions of 222 mm x 203 mm x 64 mm.

A three-phase induction motor with a rated capacity of 2 hp running at maximum speed of 1680 rpm is used to supply the required power. It is the driving component that rotates the granulating rotor. The variable frequency drive was installed to control the speed of the motor by varying the frequency supplied to the motor. To accommodate the motor, it also has a rated capacity of 2 hp.

### 3.3 Preliminary Testing

After the fabrication of the prototype, preliminary testing was done to establish the operating conditions.

To determine the operating speed, three (3) speeds were used in preliminary testing: 600 rpm, 1200 rpm, and 1680 rpm. Table 2 shows the summary of results in establishing the operating speed.

An initial speed of 600 rpm was used in the granulating process. After the test run, it was observed that considerable amounts of splattered and ungranulated crab shells were left inside the granulating chamber. These were considered potential losses. It was then decided that a higher operating speed should be applied.

Table 2. Results of preliminary testing at various operating speeds.

Mass of Feed (g)	Mass of Granulated Crab Shells at Various Operating Speeds (g)			Mass of Losses at Various Operating Speeds (g)		
	600 rpm	1200 rpm	1680 rpm	600 rpm	1200 rpm	1680 rpm
250	190	230	210	60	20	40
500	400	470	440	100	30	60
750	650	730	720	100	20	30

Another test was conducted using a higher speed of 1200 rpm. With this operating condition, no crab shell was left inside the chamber. Small amount of crab shells were somehow splattered during the operation.

The final test conducted in establishing the operating speed used 1680 rpm and it was observed that no crab shell was left inside the chamber and greater amounts of crab shells were lost during the test run. The output produced from using this speed was in powder form, which was an unacceptable particle size. Furthermore, excessive vibrations occurred and the motor easily heated up. Excessive noise was also noted during the operation of the machine.

From the results, the chosen speed was 1200 rpm because it produced an acceptable output in terms of the mass and particle size (4mm) of granulated crab shells. The machine was also in a stable condition at this speed rating.

To find the operating capacity, three (3) masses of feed (250 g, 500 g, and 750 g) were used during the testing. The machine had a good start-up speed and power. Also, no clogging was observed during the trials. Vibrations and noise were minimal while the machine was running.

When the machine was tested with 1000 g, 900 g, and 800 g, it started to clog and the motor heated up. With this, further increasing the mass of feed was rejected and the earlier three (3) masses of 250 g, 500 g, and 750 g were considered appropriate for the machine to operate well.

Table 3 shows the results of testing for determining the operating capacity using the established operating speed of 1200 rpm. The mean values with respect to mass of granulated crab shells, mass of losses, granulating time, granulating rate, and granulating efficiency were 213.33 g, 36.67 g, 49.31 s, 4.33 g/s, and 85.33%, respectively.

Results also revealed that when 500 g of dried crab shells were fed into the machine, the mean values of granulating rate and efficiency were 6.10 g/s and 89.33%, respectively. An increase in granulating efficiency was obtained from these tests.

On the other hand, the test results for 750 g mass of feed where granulating rate and efficiency increased to 8.10 g/s and 95.56%, respectively. From these test results, it was established that 750 g of dried crab shells served as the best operating capacity of the machine with a mean granulating time of about 89 sec.

Table 3. Mean results of preliminary testing in determining the operating capacity using different amounts of feed.

Mass of Feed (g)	Mean Values				
	Mass of Granulated Crab Shells (g)	Mass of Losses (g)	Granulating Time (s)	Granulating Rate (g/s)	Granulating Efficiency (%)
250	213.33	36.67	49.31	4.33	85.33
500	466.67	53.33	73.23	6.10	89.33



750	716.67	33.33	88.91	8.10	95.56
-----	--------	-------	-------	------	-------

A final test run was conducted to confirm the granulating rate efficiency using the established operating capacity of 750 g (feed), speed of 1200 rpm, and granulating time of 89 sec.

It can be gleaned from Table 4 that the obtained mean values of the granulating rate and efficiency were 8.07 g/s and 96%, respectively. An average power consumption of 0.026 kWh was recorded during the process. This final testing confirmed the granulating rate and efficiency of the machine.

### 3.4 Laboratory analysis of organic fertilizer

The properties of the product output were tested to evaluate its potential as organic fertilizer. The laboratory testing was conducted at the Lipa Quality Control Center. Table 5 revealed the laboratory analysis of organic fertilizer.

The nitrogen (N), phosphorous (P), and potassium (K) contents of the product output were 4.05%, 1.13%, and 0%, respectively. This can be compared to their theoretical values, as follows: N content of 5%, P content, 2%, and K content, 0% (Schrack, 2009). The obtained NPK values therefore were comparable to their theoretical values and can be considered as potential organic fertilizer. Further, the moisture content of 7.45%, and pH level of 8.85, with a standard range of 6.6 to 9.5, were also acceptable for application.

Table 4. Results of final performance testing using the established operating conditions (1200 rpm, 750 g, 89 sec)

Trial	Mass of Granulated Crab Shells (g)	Mass of Losses (g)	Power Consumption (kWh)	Granulating Rate (g/s)	Granulating Efficiency (%)
1	740.00	10.00	0.025	8.29	98.67
2	720.00	30.00	0.027	8.07	96.00
3	700.00	50.00	0.025	7.84	93.33
Mean	720.00	30.00	0.026	8.07	96.00

Table 5. Laboratory analysis of organic fertilizer.

Parameters	Results
Nitrogen (%)	4.05
Phosphorous (%)	1.13
Potassium (%)	0
Moisture Content (%)	7.45
pH	8.85

#### 4. CONCLUSIONS

After conducting several performance tests, results revealed the following optimal conditions: operating speed of 1200 rpm, operating capacity of 750 g, and granulating time of 89 seconds. The average granulating rate and efficiency were 8.07 g/s and 96%, respectively. Laboratory analyses showed that the nitrogen, phosphorous, and potassium contents of the product output were 4.05%, 1.13%, and 0%, respectively; hence, the obtained NPK values were comparable to the theoretical values. The moisture content of 7.45% and pH level of 8.85 were also acceptable for application. It can be concluded that the fabricated machine was capable of producing the desired output using the established operating conditions and can be considered as technically viable. The crab meal product output was considered as potential organic fertilizer in terms of its nutrient content and other properties.

#### 5. RECOMMENDATIONS

Further study may be conducted focusing on the determination of the effectiveness of the crab meal fertilizer when applied to various vegetable crops. Cost-benefit analysis may be done to evaluate the economic viability of the machine. Improved design of the granulating rotor could be integrated to minimize the losses and further increase the machine efficiency. Experts can be consulted to enhance the over-all design of the machine, ensure its reliability and maximum performance, and finally attain commercialization.

#### 6. REFERENCES

- Aganon, C. P., dela Cruz, N. E., Galindez, J. L., Patricio, M.G., & Roxas, A. C. (2004). The CLSU Ecological Solid Waste Management Project.
- Biodegradable Plastic from Crab Shells, Polymer Solutions, Materials Science Research and Innovations, 2014.
- Dela Cruz, N. E., Aganon, C. P., Patricio, M. G., Romero E. S., Lindain, S. A., & Galindez, J. L. (2006). Production of Organic Fertilizer from Solid Waste and its Utilization in Intensive Organic-based Vegetable Production and for Sustaining Soil Health and Productivity.
- Dhenge, R. M., Washino, K., Cartwright, J., Hounslow, M. J., & Salman, A. D. (2012). Twin screw granulation using conveying screws: Effects of viscosity of granulation liquids and flow of powders.
- Maghirang, R. G., De La Cruz, R., & Villareal, R. L. (2012) How Sustainable is Organic Agriculture in the Philippines. *Trans. Nat. Acad. Sci. & Tech. (Philippines)*, 33 (2), 289-318.

Manzanilla, D. O. (2006). Overview of Organic Agriculture Scope, Principles, and History.

Muir, R. (2006). Sideways into Favour.

Osborne, J., Althaus, T., Forny, L., Neideiretter, G., Palzer, S., Hounslow, M., & Salman A.D. (2013). Bonding mechanisms involved in the roller compaction of an amorphous material. *Chemical Engineering Science*, 86.

Polymer Solutions (2014). Biodegradable Plastic from Crab Shells.

Schrack, D. (2009). USDA Toughens Oversight of Organic Fertilizer: Organic fertilizers must undergo testing. *The Packer*.

Yao, H., Zheng, G., Li, W., McDowell, M., Seh, Z., Liu, N., Lu, Z., & Cui, Y. (2013). Crab Shells as Sustainable Templates from Nature for Nanostructured Battery Electrodes.